

ASSEMBLY & OPERATING INSTRUCTIONS

Save This Manual Keep this manual for the safety warnings and precautions, assembly, operating, inspection, maintenance and cleaning procedures.

Keep this manual and the receipt in a safe and dry place for future reference.

RING ROLLER

ITEM NO.:1060406



Diagrams within this manual may not be drawn proportionally.

Due to continuing improvements, actual product may differ slightly from the product described herein.



**Read this material before using this product.
Failure to do so can result in serious injury.
SAVE THIS MANUAL.**

SPECIFICATION

Ring Capacity	Unlimited
Flat Stock Capacity	4mm x 40mm
Round black ba Diameterr	4mm , 6mm, 8mm,10mm
Tube Capacity	16mm and 18mm Diameter
Drive	Gear
Rollers	Heat Treated Steel

SAVE THIS MANUAL

You will need the manual for the safety warnings and precautions, assembly instructions, operating and maintenance procedures, parts list and diagram. Keep your invoice with this manual. Write the invoice number on the inside of the front cover. Keep the manual and invoice in a safe and dry place for future reference.

SAFETY WARNINGS AND PRECAUTIONS

WARNING: When using tool, basic safety precautions should always be followed to reduce the risk of personal injury and damage.

Read all instructions before using this tool!

- 1. Keep work area clean.** Cluttered areas invite injuries.
- 2. Observe work area conditions.** Do not use machines or power tools in damp or wet locations. Don't expose to rain. Keep work area well lighted. Do not use electrically powered tools in the presence of flammable gases or liquids.
- 3. Keep children away.** Children must never be allowed in the work area. Do not let them handle machines, tools, or extension cords.
- 4. Store idle equipment.** When not in use, tools must be stored in a dry location to inhibit rust. Always lock up tools and keep out of reach of children.
- 5. Do not force tool.** It will do the job better and more safely at the rate for which it was intended. Do not use inappropriate attachments in an attempt to exceed the tool capacity.
- 6. Use the right tool for the job.** Do not attempt to force a small tool or attachment to do the work of a larger industrial tool. Do not modify this tool and do not use this tool for a purpose for which it was not intended.

- 7. Dress properly.** Do not wear loose clothing or jewelry as they can be caught in moving parts. Protective, electrically non-conductive clothes and non-skid footwear are recommended when working. Wear restrictive hair covering to contain long hair.
- 8. Use eye and ear protection.** Always wear ANSI approved impact safety goggles. Wear a full face shield if you are producing metal filings or wood chips. Wear an ANSI approved dust mask or respirator when working around metal, wood, and chemical dusts and mists.
- 9. Do not overreach.** Keep proper footing and balance at all times. Do not reach over or across running machines. Keep hands and fingers clear of the Roll Dies when operating.
- 10. Maintain tools with care.** Keep tools sharp and clean for better and safer performance. Follow instructions for lubricating and changing accessories. Inspect tool cords periodically and, if damaged, have them repaired by an authorized technician. The handle must be kept clean, dry, and free from oil and grease at all times.
- 11. Remove adjusting keys and wrenches.** Check that keys and adjusting wrenches are removed from the tool or machine work surface before plugging it in.
- 12. Stay alert.** Watch what you are doing, use common sense. Do not operate any tool when you are tired.
- 13. Check for damaged parts.** Before using any tool, any part that appears damaged should be carefully checked to determine that it will operate properly and perform its intended function. Check for alignment and binding of moving parts; any broken parts or mounting fixtures; and any other condition that may affect proper operation. Any part that is damaged should be properly repaired or replaced by a qualified technician. Do not use the tool if any switch does not turn on and off properly.
- 14. Replacement parts and accessories.** When servicing, use only identical replacement parts. Use of any other parts will void the warranty. Only use accessories intended for use with this tool.
- 15. Do not operate tool if under the influence of alcohol or drugs.** Read warning labels if taking prescription medicine to determine if your judgment or reflexes are impaired while taking drugs. If there is any doubt, do not operate the tool.
- 16. Maintenance.** For your safety, service and maintenance should be performed regularly by a qualified technician.
- 17. Workpiece may be sharp.** After bending or cutting workpieces use caution. Be aware of sharp edges or sharp shreds of metal that may be created. Use heavy duty gloves when handling the workpiece.

WARNING: The warnings, cautions, and instructions discussed in this instruction manual cannot cover all possible conditions and situations that may occur. It must be understood by the operator that common sense and caution are factors which cannot be built into this product, but must be supplied by the operator.

UNPACKING

When unpacking, check to make sure that all parts shown in the Parts Diagram are included. If any parts are missing or broken, please contact the seller.

ASSEMBLY

Your Ring Roller will require minor assembly prior to operation. It is important that you read the entire manual to become familiar with the BEFORE you assemble and use the Ring Roller. Before assembling your Ring Roller be sure that you have all parts described in the Parts List.

When assembling your Ring Roller, it will be helpful to refer to each of operational Figures as well as to the Parts List and Assembly Diagram on the last pages of this manual.

Assemble attachments based on the intended use of the Ring Roller only.

Mounting Surface: The mounting surface must be flat, level and capable of supporting the weight of the Roller combined with the materials to be rolled. Mount the Ring Roller on a solid mounting surface that is capable of supporting the weight of the Ring Roller and the leverage force of the Handle movement.

1. Slide the Handle (15#) onto the Drive Shaft, make certain that the holes in the Handle (15#) line up with the hole in the Drive Shaft. see **Figure 1**.

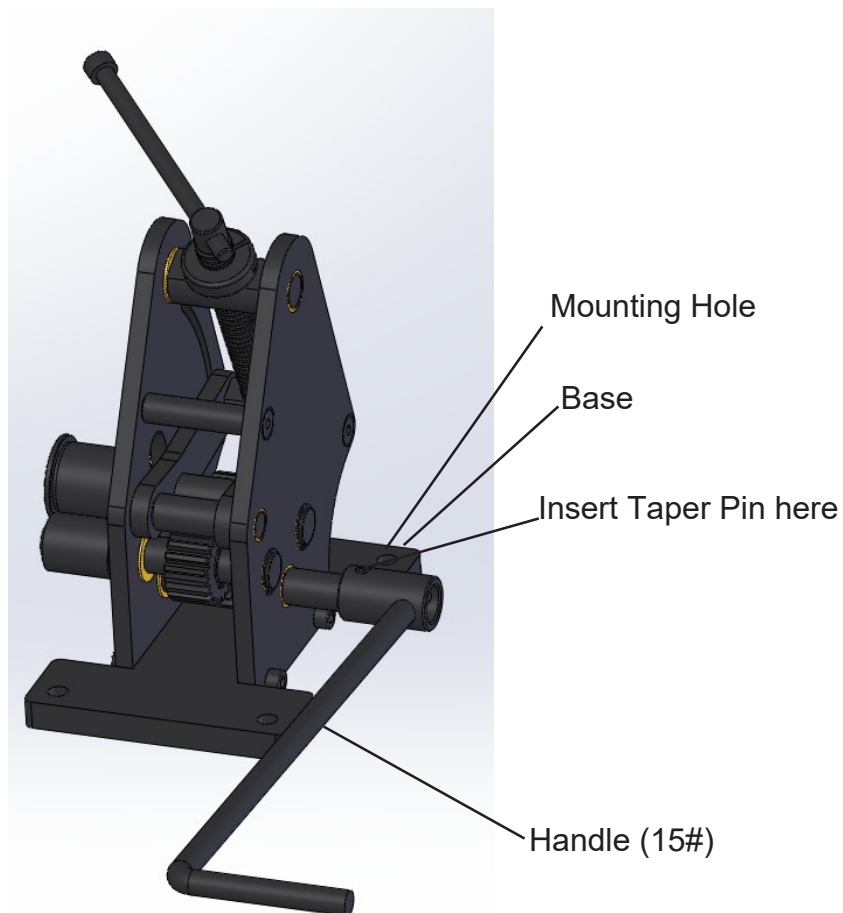

Figure 1

2. Secure the Handle (15#) to the Drive Shaft using the Taper Pin . Insert the Taper Pin into the hole as seen in **Figure 1**. If necessary, lightly tap the Taper Pin into place.

Mounting:

1. Set the Roller on your appropriate mounting surface as desired.

Warning: The Metal Planetary Ring Roller must be securely mounted to an appropriate work surface prior to use!

2. Make certain that you can operate the Handle (15#) comfortably.
3. Make appropriate mounting surface through the four holes located at the far ends of the Base .
4. Remove the Metal Planetary Ring Roller from the appropriate mounting surface. Drill holes through the mounting surface at the marked locations.
5. Mount the using four bolts, lock washers, washers and nuts (in that order) sold separately.

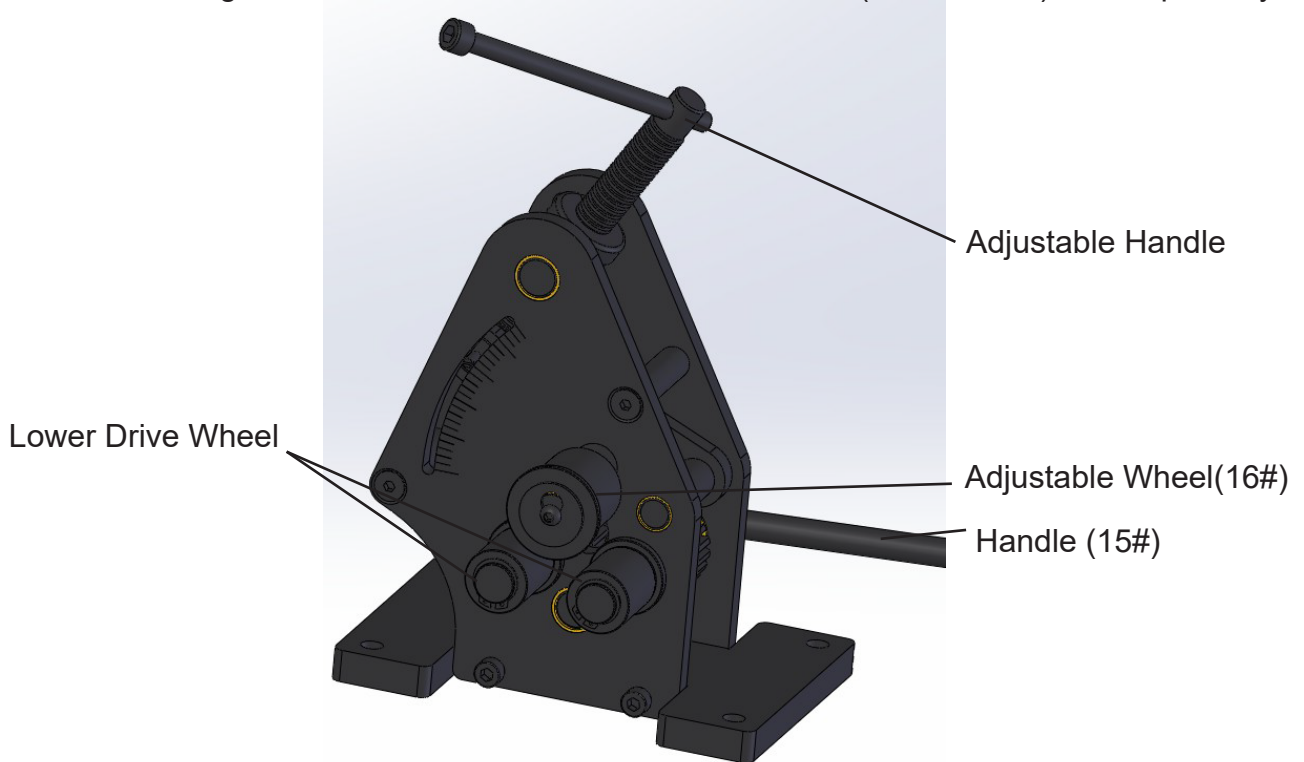

Figure 2

OPERATION

Operation When operating your Metal Planetary Ring Roller, it may be helpful to refer to each of the operational Figures as well as to the Parts List and Assembly Diagram located on the last pages of this manual. Never force the tool or attachment to do the work of a larger industrial tool. It is designed to do the job better and more safely at the rate for which it was intended.

1. Determine the size ring you wish to produce.**NOTE: Do not use flat stock or round stock larger than listed in the specifications**
2. Move the Adjustable Wheel (16#) up or down (as desired) by turning the Adjustable Handle. see **Figure 2**.
3. To obtain small size rings , the Adjustable Wheel (16#) must be in its lowest position.
4. To obtain 2” rings, the Adjustable Wheel (16#) must be in the middle position.
5. To obtain larger rings, the Adjustable Wheel (16#) must be in its uppermost position.It is recommended that you practice on scrap stock to find the correct wheel adjustment to make the desired size ring.
6. Insert the stock between the Adjustable Wheel and the Lower Drive Wheel.
7. Turn the Adjustable Handle clockwise to clamp the stock between the Wheels.
Warning: After stock has been clamped between the Wheels, keep hands and fingers clear of the Wheels while the handle is being rotated.
8. Rotate the Handle (15#) to process the ring
9. To remove the completed rings, turn the Adjustable Handle to loosen the clamping action.

PARTS LIST

ITEM	DESCRIPTION	QTY.
1	C-Ring	10
2	Left Frame	1
3	Key 5mm	4
4	Flat Lower Wheel	2
5	Screw M5X20	1
6	Screw M8X10	2
7	Adjustable Seat	1
8	Space Shaft	2
9	Bushing	6
10	Bushing	4
11	Right Frame	1
12	Bushing	6
13	Screw M6X16	1
14	Screw M8X20	4
15	Handle	1
16	Adjustable Wheel	1
17	Drive Shaft	2
18	Shaft	1
19	Drive Gear Shaft	1

ITEM	DESCRIPTION	QTY.
20	Gear	1
21	Screw M8X20	4
22	Screw M6X10	1
23	Pin 5X24	1
24	Pin 8X30	1
25	Hex Key S=4	1
26	Base	1
27	Screw	1
28	Adjustable Handle	1
29	Small Lower Round Bar wheel	2
30	Small Upper Round Bar wheel	1
31	Big Lower Round Bar wheel	2
32	Big Upper Round Bar wheel	1
33	Washer	1
34	Collar	1
35	Safety Plate	1
36	Safety Plate	1
37	Washer	1

ASSEMBLY DIAGRAM

