

**Instructions and Maintenance**  
**Original Manual**  
**QJY2.5-H**  
**Movable single post lift**

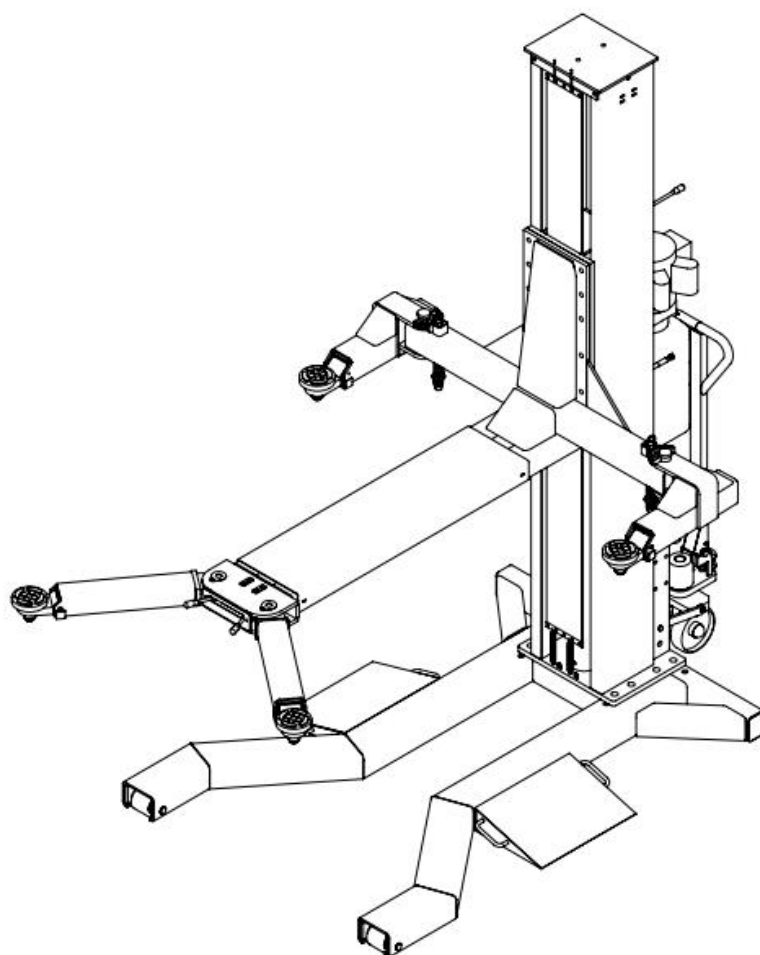

## Content

1.Safety.....	2
1.1Introduction.....	2
1.2IntendedUse .....	2
1.3 SafetyInstructions for Commissioning.....	2
1.4 SafetyInstructions for Operation .....	2
1.5 SafetyInstructions for Servicing .....	2
1.6 Safety featuresl.....	3
1.7Disposal of usedoil.....	3
1.8Machine demolition.....	3
2. StructureDrawing:.....	3
3.Main TechnicalMechanismParameters Table.....	5
4.Packing, transport and storage.....	5
4.1Packing.....	5
4.2Lifting andhandling.....	5
4.3 Storage and stackingofpackages.....	6
4.4Delivery and check ofpackages.....	6
5Installation.....	6
5.1Working Site.....	6
5.2Installation.....	6
6. Operationinstruction.....	7
6.1 OperationRules for mechanismSystem .....	7
6.2 Operating Steps for ElectricalControlSystem.....	7
6.3 OperationFlow:.....	7
6.4Uselifting arm.....	9
6.5ControlUnit.....	10
7.Maintenance and Troubleshooting.....	10
7.1Maintenance.....	10
8. Troubleshooting .....	11
Appendix.....	13
1Exploded drawing .....	13
2 Circuitdiagram.....	14
3Hydraulic diagram.....	15

# 1. Safety

## 1.1 Introduction

Thoroughly read this manual before operating the lift and comply with the instructions. Always display them annual in a conspicuous location.

Personal injury and property damage incurred due tonon - compliance with these safety instructions are not covered by the product liability regulations.

## 1.2 Intended Use

This single column vehicle lift is classified as movable model. Movable single column Vehicle lift is specially useful for indoor. It is the special equipments for lifting vehicles, such as cars, which park on ground, to a certain height for maintenance. It is forbidding to park vehicles. Observe the rated load capacity and load distribution of the lift.

## 1.3 Safety Instructions for Commissioning

⚠ The lift may be installed and commissioned by authorized service personnel only. ⚠ The standard lift version may not be installed and commissioned in the vicinity of explosives or flammable liquids, outdoors or in moist rooms (e.g. car wash).

## 1.4 Safety Instructions for Operation

- ⚠ Read the operating manual.
- ⚠ Lift operation by authorized personnel over 18 years only.
- ⚠ Always keep the lift and lift area clean and free of tools, parts, debris etc.
- ⚠ Once the disk adapters contact the lift points, check arm restraints for engagement.
- ⚠ After raising the vehicle briefly, stop and check the disk adapters for secure contact.
- ⚠ Always lift the vehicle using all four adapters.
- ⚠ Make sure the vehicle doors are closed during raising and lowering cycles.
- ⚠ Closely watch the vehicle and the lift during raising and lowering cycles.
- ⚠ Do not allow anyone to stay in lift area during raising and lowering cycles.
- ⚠ Do not allow anyone on lift or inside raised vehicle.
- ⚠ Only use the lift for its intended purpose.
- ⚠ Comply with the applicable accident prevention regulations.
- ⚠ Do not overload the lift. The rated load capacity is indicated on the lift nameplate.
- ⚠ Only use the vehicle manufacturer's recommended lift points.
- ⚠ After positioning the vehicle apply the parking brake.
- ⚠ Use caution when removing or installing heavy components (center-of-gravity displacement).
- ⚠ The main switch serves as emergency switch. In case of emergency turn to OFF position.
- ⚠ Protect all parts of the electrical equipment from humidity and moisture.
- ⚠ Protect the lift against unauthorized usage by pad locking them in switch.

## 1.5 Safety Instructions for Servicing

- ⚠ Maintenance or repair work by authorized service personnel only.
- ⚠ Turn off and pad lock them in switch before doing any maintenance, or repair work.

- ⚠️ Work on generators or proximity switches by authorized service personnel only.
- ⚠️ Work on the electrical equipment by certified electricians only.
- ⚠️ Ensure that ecologically harmful substances are disposed of only in accordance with the appropriate regulations.
- ⚠️ Do not use high pressure/steam jet cleaners or caustic cleaning agents.
- ⚠️ **Risk of damage!**
- ⚠️ Do not replace or override the safety devices.

## **1.6 Safety Features**

### **1.6.1 Hold-to-run Type Control**

The operator is required to hold the controls in the engaged position to raise or lower the lift.

### **1.6.2 Equalizing System**

The lift is provided with distributing and connecting flow valve to ensure level movement of both carriages.

### **1.6.3 Pipe Break Valve**

The hydraulic cylinders are equipped with pipe break valves. They respond in case of rapid pressure drop (line break) to prevent sudden lowering movements.

### **1.6.4 Pressure Relief Valve**

A pressure relief valve is used to limit the hydraulic working pressure to a maximum of 200bar.

## **1.7 Disposal of used oil**

Use the oil, which is removed from the power unit and the plan during an oil change, must be treated as a polluting product, in accordance with the legal prescriptions of the country in which the lift is installed.

## **1.8 Machine demolition**

The machine must be demolished by authorized technicians, just like for assembling. The metal parts can be scrap pedasiron. In any case, all the materials deriving from the demolition must be disposed of in accordance with the current standards of the country in which the rack is installed. Finally, it should be recalled that for tax purposes, demolition must be documented; submitting claims and documents according to the current laws in the country in which the rack is installed at the time the machine is demolished.

## **2. Structure Drawing:**

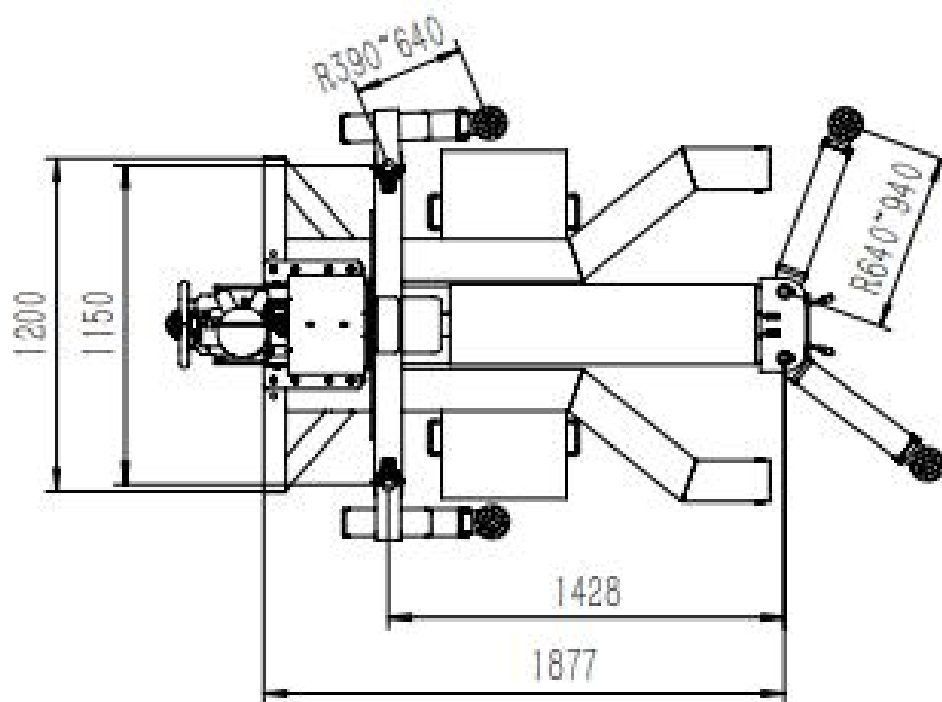
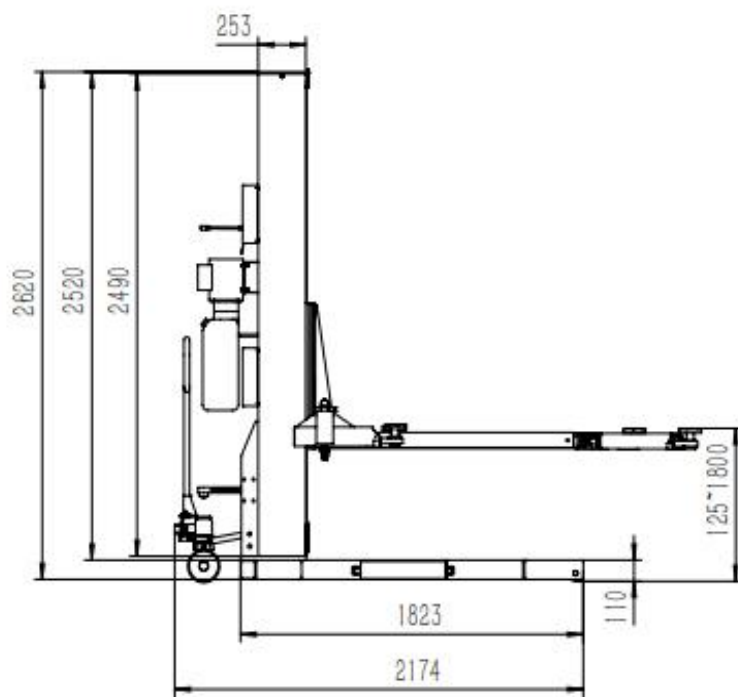

### 3. Main Technical Mechanism Parameters Table

Name \ Model	QJY2.5-H
Lifting capacity:	2500kg / 3000kg
Max. lifting height	1800mm
Minimum lift height	125 mm
Rated oil pressure	18MPa
Noise	<70dB
Working environment temperature	-5°C/+40°C
Working environment	Indoors
Power	2.2kw
Working voltage of control system	24V
Voltage	110V/220V/380V
Safety catch	Manual

### 4. Packing, transport and storage



Only skilled personnel who are familiar with the lift and this manual shall be allowed to carry out packing, lifting, handling, transport and unpacking operations.

#### 4.1 Packing

90% components were pre-assembled before shipment, and packed with blister packing in steel frame. Arms, adapters and rubber pads were put in the lift. Power unit was packed in carton box separately, power unit stand was packed and fixed on above the lifts.

#### 4.2 Lifting and handling

When loading/unloading or transporting the equipment to the site, be sure to use suitable loading (e.g. cranes, trucks) and hoisting means. Because also to hoist and transport the components securely so that they cannot drop, taking into consideration the package's size, weight and centre of gravity and it's fragile parts.

### **4.3 Storage and stacking of packages**

Packages must be stored in a covered place, out of direct sunlight and in low humidity, at a temperature between -10°C and +40°C.

### **4.4 Delivery and check of packages**

When the lift is delivered, check for possible damages due to transport and storage; verify that what is specified in the manufacturer's confirmation of order is included. In case of Damage in transit, the customer must immediately inform the carrier of the problem.

Packages must be opened paying attention not to cause damage to people(keep a safe distance when opening straps) and parts of the lift (be careful the objects do not drop from the package when opening).

## **5 Installation**

### **5.1 Working Site**

The user should prepare the working site for the lift before its arrival

**5.1.1 Power Source** The working site must be equipped with certain power. Install safety distribution box with a 4-hole socket around the operation position.

**5.1.2 Ground** The lift must be placed on flat and hard ground, which is made of cement or bricks, with the load at the position of vertical post of 3t/m<sup>2</sup>.

**5.1.3 Working Area** There should be >about 1,000mm space around the vehicle lifted, and the net height in door is about 3600mm.

### **5.2 Installation**

Because of the limitation of transportation, lift shall be disassembled to pack. The users should assemble the lift according to the following figure:

Assemble movable single column lift

Overall assembly as follows:

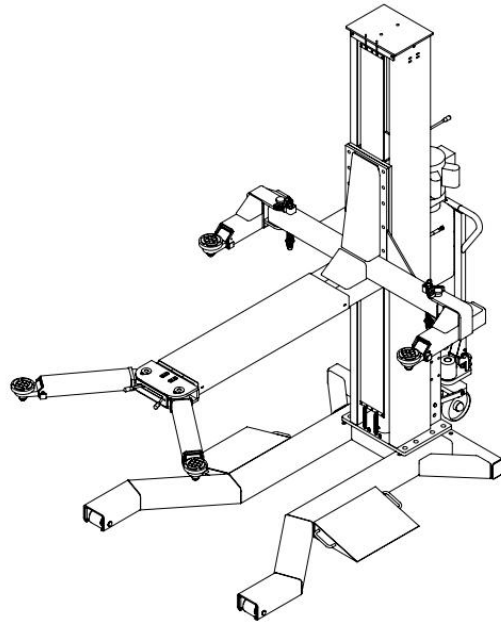

## **6. Operation instruction**

### **6.1 Operation Rules for mechanism System**

6.1.1 The movable single column lift is provided with separate traveling mechanism.

Shake the hauling handle of the steering rear wheel forwards and backwards to make the vertical column off the ground, then you can push or pull the lift. On arriving the working site, press the valve handle to retract the wheel, then the vertical column lands on the ground steadily.

6.1.2 The lift must only be pushed into the vehicle if in line with it. Insert the pallet under the vehicle beam and the pallet must be in line with the beam.

6.1.3 Retract the rear wheel of vertical post to land the vertical post steadily before the lift lifts load, and make sure there is no foreign article such as hand tools, bolts, screw caps, small stones. No lifting during moving!

### **6.2 Operating Steps for Electrical Control System**

New machine is operated for commissioning without load before its first use. The electrical box is provided with "0-1" main power switch, which should be turned off after the machine use finished.

### **6.3 Operation Flow:**

- 1) Vehicle stops in the service position with engine off
- 2) Turn the handle for hydraulic movable wheel to lift the vertical post base a bit
- 3) Push the lift into the underside of vehicle
- 4) Make sure there is no foreign articles under the base and the ground is level
- 5) Grasp the valve handle to make the base lowered to ground
- 6) Align 4 pallets on the lifting arm respectively to the supported positions on the vehicle underside
- 7) Press the “green” button to raise the vehicle by 10~15 centimeters
- 8) Stop the vehicle raising and check for safe and secure four high points of the pallet.
- 9) Check if the main lifting arm touches the vehicle bottom plate, which should not occur during normal lifting.
- 10) Pull the safety unlock handle to make the lifting platform unlocked.
- 11) To adjust lifting pad, turn it anticlockwise to make it rise  
(adjustment distance of 100mm)
- 12) Press the “green” button again and pay attention to lifting arm and the vehicle lifted until lifting is safe and reliable.
- 13) Raise the lift to the required height, then lower it to the lock position
- 14) After the repair of vehicles finished, raise the lift about 2-3cm, pull the release cable on the column, then push the lowering handle on power unit to lower the lift.
- 15) Turn the handle of hydraulic pump and the lift is off the ground, pull out the lift.
- 16) Drive the vehicle away.

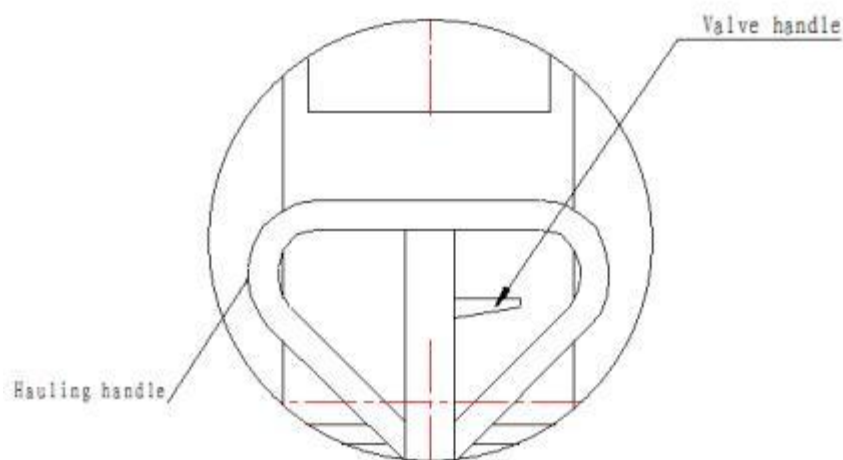

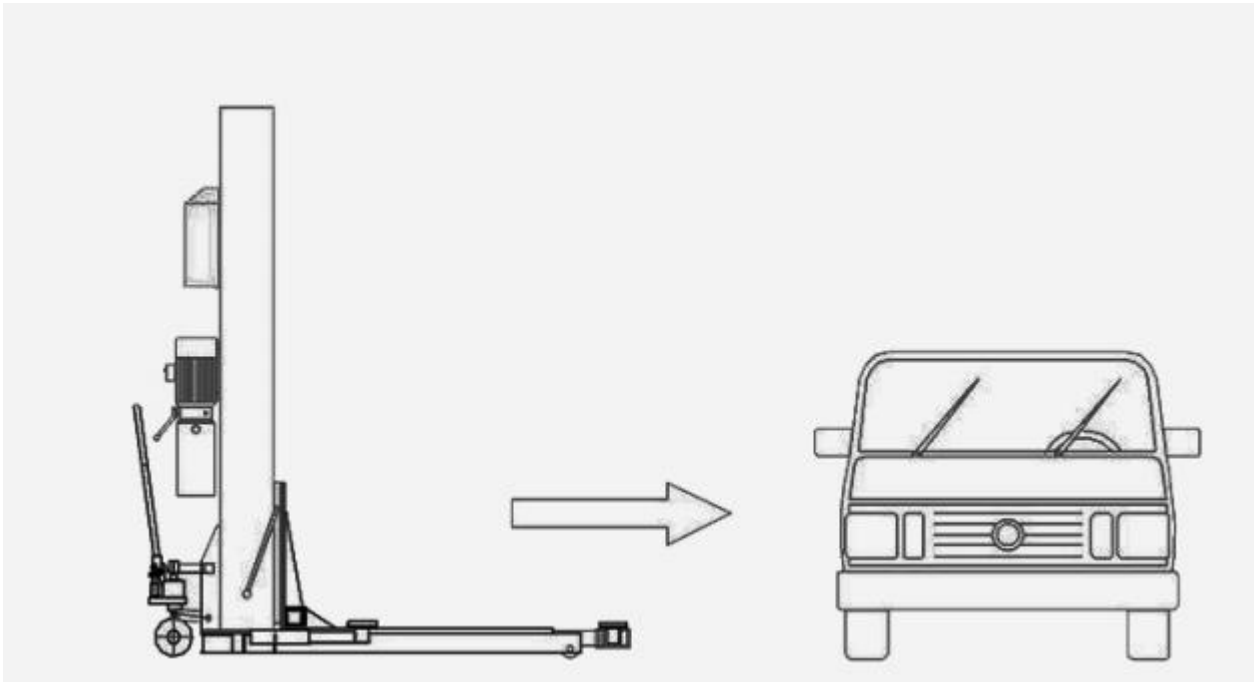

**Movable lift pushed into the underside of the vehicle**

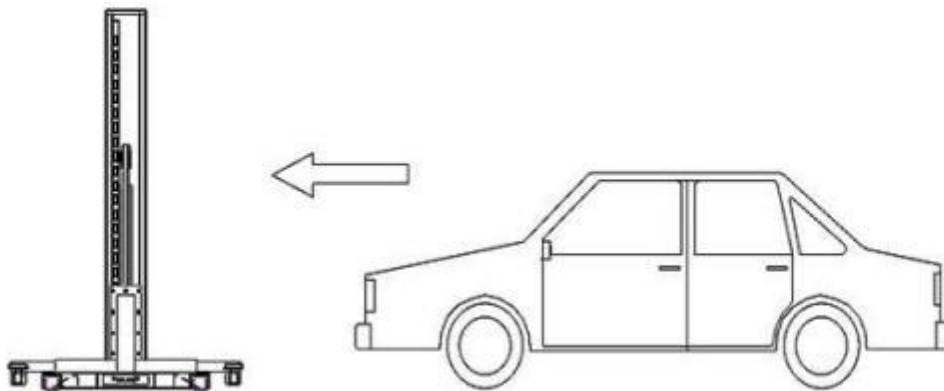

**Vehicle driving on to the lift**

## **6.4 Use lifting arm**

### **7.4.1 Movable Lift**

- a. According to the position under the vehicle chassis where the lifting arm is located, the supporting arm on the lifting arm (close to the vertical post) maybe pushed and pulled up and down or to left and right:

- b. The supporting arm in the front of lifting arm maybe turned or pushed or pulled inward or outward, or to left and right.
- c. The height of pallet can be adjusted by turning it clockwise or anticlockwise.

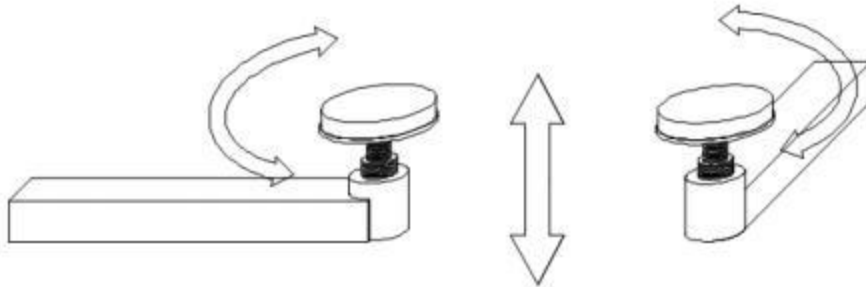

## 6.5 Control unit



Release handle

## 7 Maintenance and Troubleshooting

### 7.1 Maintenance

7.1.1 For daily maintenance and service of the lift, see operation steps, use and cautions described in the previous page.

7.1.2 The working environment and the surface of this machine should be cleaned usually.

7.1.3 During the use of this machine, if any oil leaking is found, check the leakage source. Check whether the screw of the hydraulic oil hose is tighten, if it is loosen, it should be tighten. After this step, if the leaking problem still occurs, check whether the seal kit of the cylinder is damaged, if it is damaged, it must be replaced.

#### 7.1.4 Month Care

Below maintenance should be done once every month.

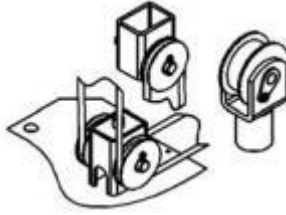
No.	Content of maintenance	Method	Sample drawing
①	Check if the rubber pad of the arms are damaged or not	New replacement	
②	Check whether the bolts, nuts, pins, etc. on all parts are normal	Reinforcement, clean-up or new replacement	
③	Check the shaft, sprocket, chain, wire wheels, wire rope position whether they are normal	lubrication, re-adjust	
④	Check the clean of sliding parts and safe insurance situation	Lubrication、re-adjustor new replacement	

⑤	Check hydraulic system connections and ensure no leakage of fuel tank	Visual and tighten with the wrench, and clean oil	
---	---	---	---

## 8 Troubleshooting

### If lifting is impossible:

Check the power, interchange any two wires of three-phase wire and try lifting again. Because the phase sequence of power does not conform to the adjusted phases sequence when motor and pump is operating.

### If lifting is possible but impossible to load **2.5T**

Adjust the fluid valve. It is possible to press the “▲” button while turn the screw clockwise slowly, until the lifting arm rises.

### If lifting is still impossible after above actions have been taken

Remove fluid valve and put it into diesel oil to wash. After that, install it again and operate according to above action once more.

### If there is any abnormal noise from hydraulic system during lifting

The hydraulic system may in hale air or the power voltage is too low. Check the oil level and add oil if necessary. Move the cylinder up and down for several times to expel the air.

# Appendix

## 1 Exploded drawing

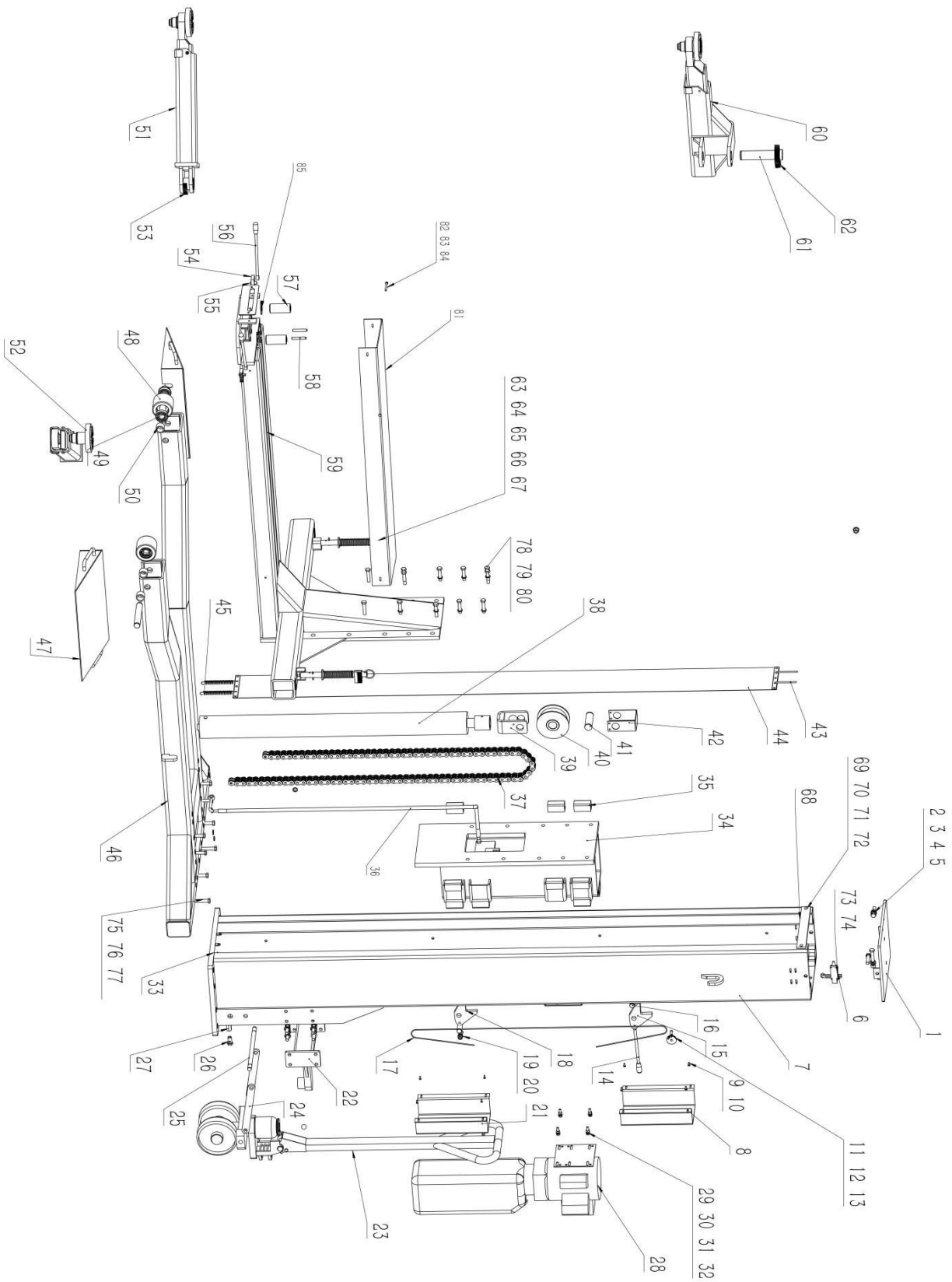

No:	Name	Qty	No:	Name	Qty
1	Top Cap	1	44	Column cover	1
2	M12*35 screw	11	45	spring	2
3	flat gasket	11	46	Base welding	1
4	spring washer	11	47	Car board components	2
5	M12 blind nut	11	48	Floor roller	2
6	limit switch	1	49	Floor roller	2
7	Column components	1	50	Floor roller axle sleeve	4
8	Main lock cover	1	51	Front support arm assembly	2
9	M5*10screw	8	52	salver	4
10	flat gasket	8	53	Front lock tooth 1	2
11	rope sheave	2	54	Front lock tooth 2	2
12	Rope wheel shaft	2	55	Front lock tooth shaft	2
13	cotter; split pin	4	56	Unlock the handle in front	2
14	Lock the handle	1	57	Front support arm shaft	2
15	Main lock plate	1	58	Front handle shaft	2
16	Lock shaft	2	59	Sliding arm components	1
17	Unlock the rope	1	60	Rear support arm assembly	2
18	Sub-lock plate	1	61	The rear arm shaft	2
19	Rope wheel fixed shaft	2	62	Rear support arm lock 1	2
20	M10 Fixed nut flat pad	4	63	Rear support arm lock 2	2
21	Deputy lock cover	1	64	The rear lock shaft	2
22	Pull rod components	1	65	Rear lock spring	2
23	pull a cart	1	66	lat gasket	2
24	Pull the car fixed board	4	67	Small pin	2
25	Pull the car pin shaft	2	68	Safety insurance board	1
26	Oil pipe joint	1	69	M10 screw	2
27	Oil pipe elongation rod	1	70	flat gasket	2
28	power unit	1	71	Fixed pad	2
29	M8*20 screw	4	72	M10 blind nut	2
30	flat gasket	4	73	M5*25 screw	4
31	spring washer	4	74	M5 blind nut	4
32	M8blind nut	4	75	Base plate screw M20 * 60	10
33	Bottom plate components	1	76	flat gasket	10
34	Slip assembly	1	77	spring washer	10
35	Nylon block	12	78	Slide arm screw M16 * 45	10
36	oil pipe	1	79	flat gasket	10
37	chain	1	80	spring washer	10
38	hydro-cylinder	1	81	cover	1
39	Oil cylinder assembly	1	82	M5*25 screw	2
40	pulley	1	83	flat gasket	2
41	Oil cylinder shaft	1	84	spring washer	2
42	Oil cylinder cover	1	85	Front support arm lock spring	1
43	Dust cloth hook	2			

## 2 Circuit diagram

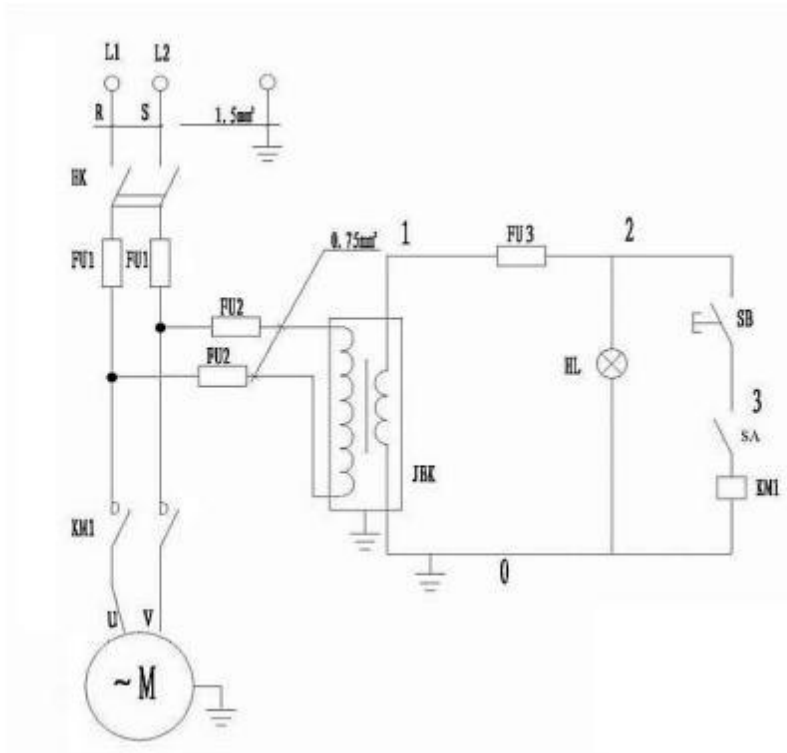

## 3 Hydraulic diagram

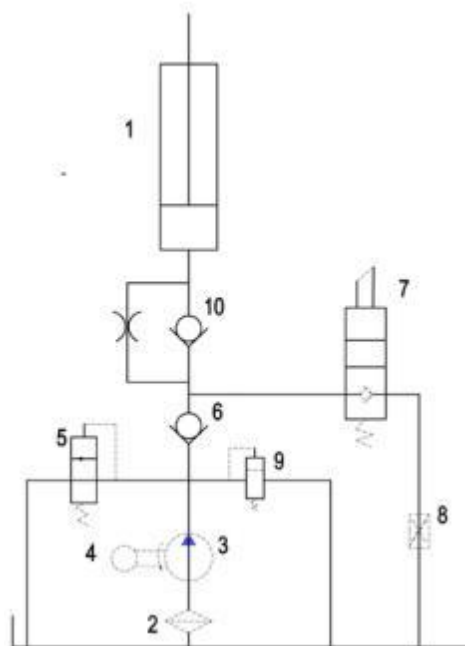

No	Name	No	Name	No	Name
1	Tank	5	Start buffer valve	9	Relief valve
2	Filter	6	One-way valve	10	Anti-explosion valve
3	Oil pump	7	Release valve	11	
4	Motor	8	Return oil throttle valve		